

Flowban™

Stops an Overflow

Installation Instructions

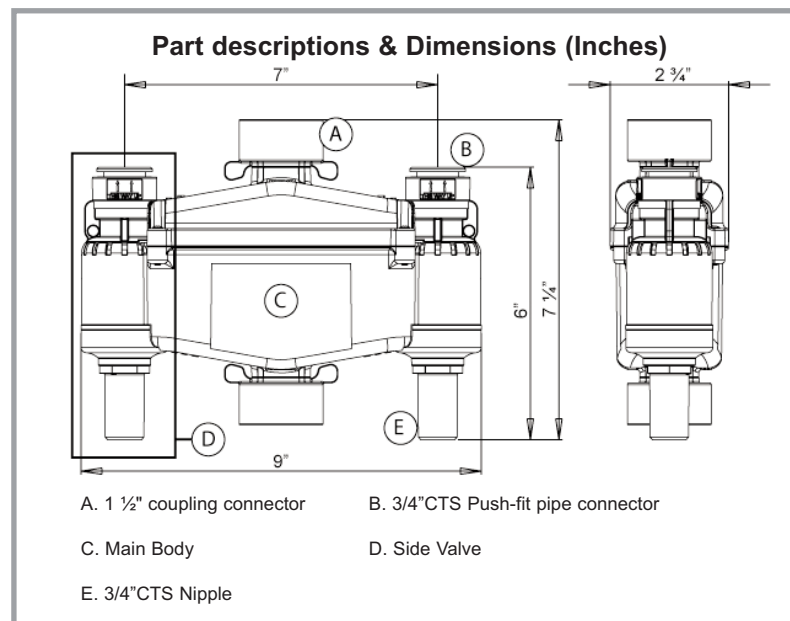
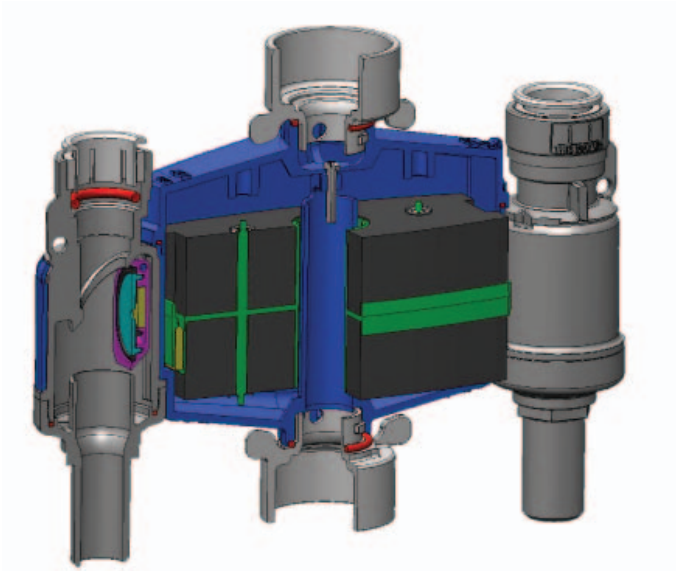

Tested to comply with IGC 241 - 2008a UPC Model # NF/FB01

www.flowban.com

Designed and made in the United Kingdom



NFAXXUSX.AW02

© About Time Design Ltd 2009

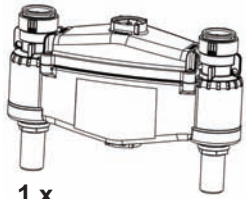

1 x
Flowban™ unit



2 x
1 1/2" coupling
connector



2 x
O-ring for
coupling
connector

Congratulations on purchasing a Flowban™ water wastage and flood prevention device.

Flowban™ shuts off the water supply to the faucets when the water level in the bath or basin reaches the overflow outlet. It saves water by preventing overflowing, reducing water consumption and saving on the energy used to heat water. Flowban™ also will stop a flood occurring in the case where the overflow is insufficiently sized to deal with the volume of incoming water. It can save substantial costs that may be caused by flood damage.

Suitable waste and overflow fittings.

Flowban™ cannot be installed on a waste and overflow fitting which has any kind of waste activating mechanism passing down the overflow pipe. It is not possible to use a "Snake" for cleaning the drain with Flowban™ installed.

Recommendation

Bathtubs, faucets and overflows differ greatly and care must be taken to understand the individual plumbing arrangements prior to undertaking any installation.

Ensure you can isolate the supply water and are familiar with work of this nature.

We recommend you always use a licensed plumber to install a Flowban™ unit.

Orientation

The Flowban™ unit must be fitted in a vertical plane. It must not be fitted lying flat or at an angle since this will hinder operation. Directions for orientation are clearly marked on the main body of the Flowban™ unit.

Positioning

The Flowban™ unit must be located between the overflow outlet (**See Fig. 1**) and the waste in a position as high as can be reasonably achieved. This position will allow any excess water flowing through the overflow outlet from the bath or basin to pass through the Flowban™ unit causing activation of the valves to shut off the supply water. The positioning of the Flowban™ unit is the same for all types of installations.

Connection to overflow pipe

Standard Fernco or equivalent waste connectors should be used to attach the 1 1/2" coupling connector. The recommended fittings are:-

Brass Wastes 2 No. Fernco Proflex 3002-150

Plastic Wastes 1 No. Fernco Proflex 3000-150

1 No. Fernco PlumbQuik 1056-150

To allow for vertical movement of the coupling connector when the unit is being installed or when it is removed for servicing we recommend minimum dimensions of the overflow pipe for both brass and plastic wastes. There should be a gap of 7 1/4" in the pipe and a minimum height of 3 1/2" of pipe above the gap and 1 1/4" below the gap. (**See Fig. 2**)

If the overall length of 12 1/4" cannot be achieved, the absolute minimum height of the assembled unit including Fernco Proflex 3000-150 connectors top and bottom is 9 1/2" on a plastic waste. (**See Fig. 3**)

If using a brass waste you will be able to slide the 3002-150 fittings up and down the pipe and the pipe will also travel inside the coupling connectors to give extra room for movement in the vertical plane.

On plastic wastes the flexible connector 1056-150 will move up or down the pipe to provide vertical movement should removal be required.

Once the Flowban is correctly installed on a rigid waste overflow pipe it will require no other form of attachment or stiffening.

Ensure all fittings are watertight by looking for leaks during testing once the installation is complete.

Fig. 1 Installation recommendation

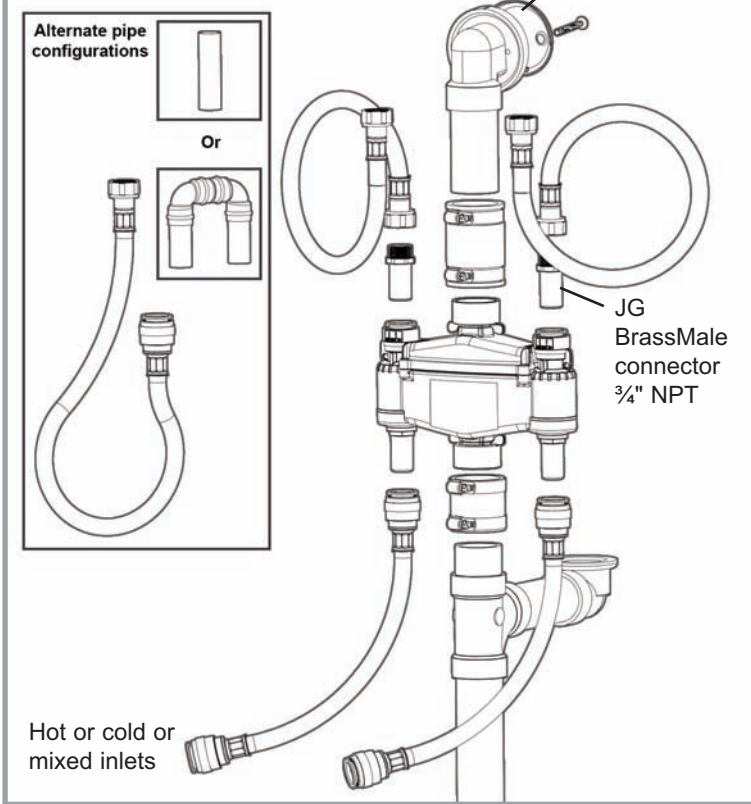

Water supplies

The two side valves are completely independent of each other. A single side valve can be used leaving the other side valve unconnected. Either valve can be fed with hot or cold water or pre-mixed water. Pre-mixed water can be connected to a single side valve or the flow can be split to each side valve and reconnected the other side of the Flowban unit.

The faucet control can be located on the water supplies either before or after the Flowban unit. There is considerable flexibility as to how the controls and inlet lines are configured to suit individual plumbing and faucet control scenarios.

Normal hot and cold supplies. (See Fig. 1) The inlet supplies should be connected to the nipples using a John Guest Speedfit 3/4" NPT fitting on a flexible hose. The outlets on the top should be connected to the faucets using a flexible hose with John Guest Brass Male Connector 3/4" NPT Part No. MWI 0152826 or equivalent.

Flowban™ is rated at a maximum continuous hot water temperature of 150 degrees Fahrenheit.

Fig. 2 Recommended overflow fitting dimensions

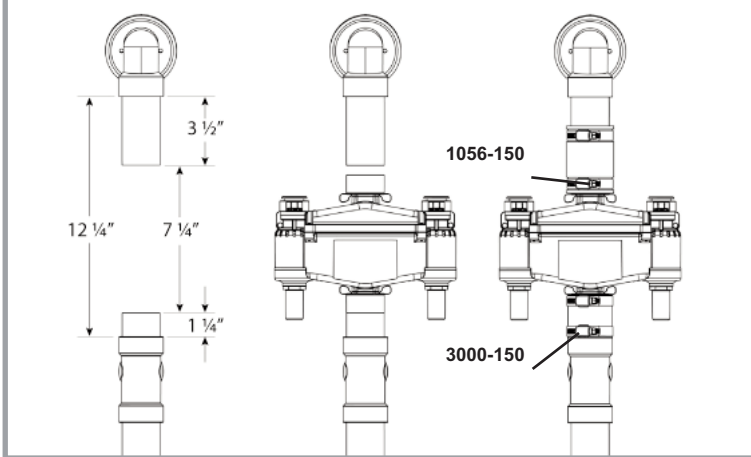

Flowrate

The maximum flow rate through each of the ports is 18 gallons per minute. If this rate is likely to be exceeded the flow should be restricted to stop unintentional valve actuation

Purging of system

The system, once fitted will need to be purged to clear any air inside the system. This is done by allowing the faucets to flow at full rate for 1 minute, then turning them off. Repeat this procedure three times. Should the valves actuate, simply turn off the faucets, wait for five seconds then turn them on gently. Once the system is purged of air, unintended activation of the valves such as this will not occur.

Fig. 3 Minimum fitting dimensions

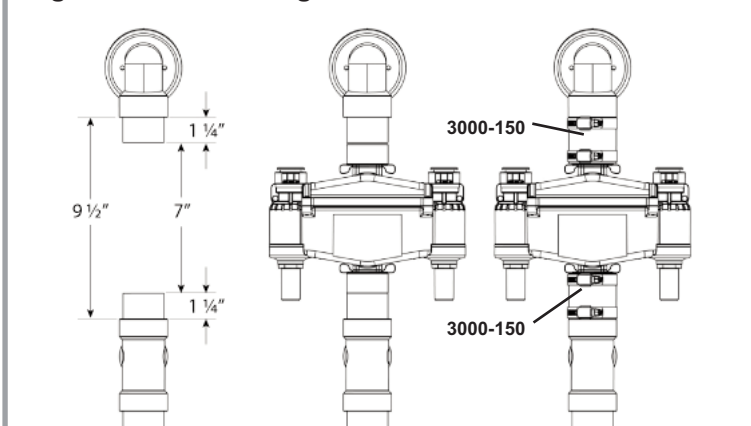

Testing

Test for leaks before replacing any bath surround or cladding.

Normal operation and reset.

When water enters the overflow outlet the float in the central chamber rises and magnets activate the valves that shut off the flow to the faucets. A small trickle of water remains which indicates that the faucets are still open. The unit will only reset itself when the faucets are closed and there is no more water going down the overflow outlet.

Maintenance

To ensure correct operation of Flowban™, you are advised to check its operation once every six months. To do this, use the water from a shower head or a hose connection directed into the overflow whilst the faucets are running.

If the float activating mechanism ever becomes clogged with soap, hair or other debris that has entered from the overflow inlet the unit must be removed and cleaned.

Most debris will collect in the bottom so removing the lower pipe connector by rotating it 45 degrees counter clockwise will allow cleaning of this area.

To clean the whole float chamber, remove the five screws on the top of the unit and lift out the float. After cleaning ensure that the float is replaced the correct way up (**See Fig. 5**) otherwise the unit will not function. Do not use abrasive cleaners. Upon reassembly care must be taken not to overtighten the screws.

WARRANTY

Flowban™ (the device) is warranted to be free of defective parts, material and construction at time of supply. The device is intended for occasional use as a preventative device and should not be used as a means of automatically setting your bathtub water level on a regular basis.

About Time Design Ltd (the company) and our suppliers take no responsibility for the quality of fitment of Flowban™ or any loss or damage caused by defective installation. We recommend installation by a licensed plumber to ensure there are no leaks and that the device performs according to specification. The company takes no responsibility for consequential loss under any circumstances.

In event of queries, in the first instance please contact us on:

email: info@flowban.com

Fig. 4

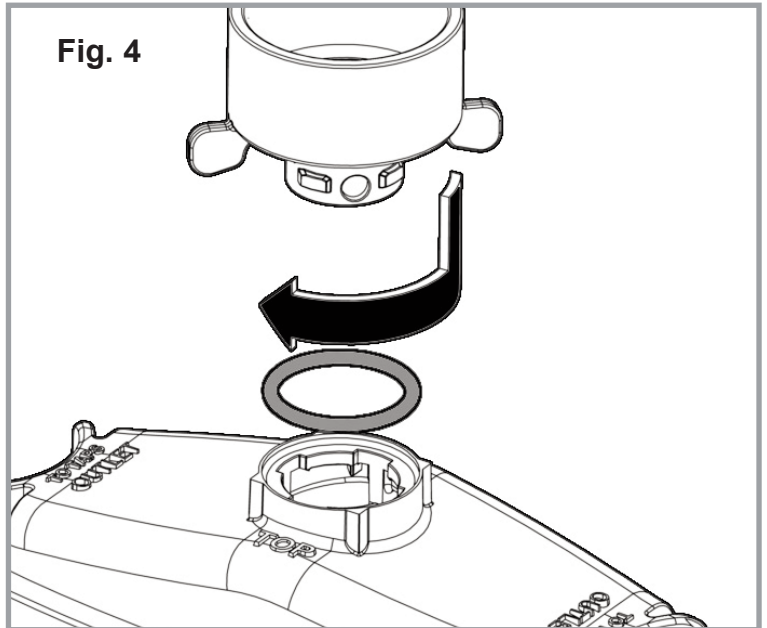
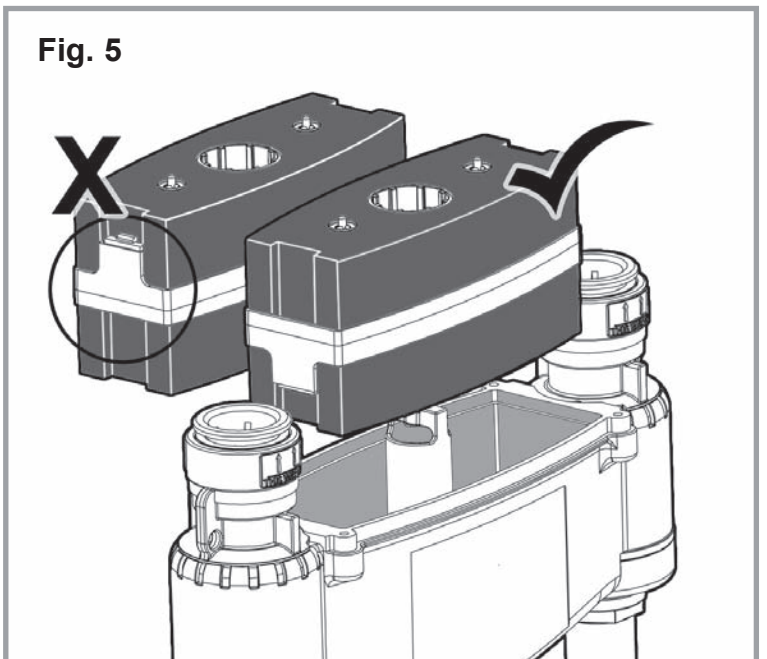

Fig. 5



WARNINGS

Don't put fingers or other body parts into apertures or plumbing fittings on the unit! These can contain sharp edges.

Use a pipe cutter to cut any pipe. Do not use a hacksaw as this can leave a jagged and off-square cut which could damage the Flowban™ unit upon insertion.

Do not use soldered or compression fittings or solder flux in direct contact with the unit.

Care must be taken to avoid any heat transfer to the unit if soldering fittings in close proximity.